



REMKO CLK 80-RV CLK 170-RV

Oil heaters

Operation · Technology · Replacement parts



Contents

<i>Safety notes</i>	4
<i>Unit description</i>	5
<i>Installation instructions</i>	6
<i>Safety device</i>	7
<i>Exhaust ducting</i>	8
<i>Before commissioning</i>	9-10
<i>Commissioning</i>	10-11
<i>Shutdown</i>	11
<i>Care and maintenance</i>	12-14
<i>Troubleshooting</i>	14
<i>Intended use</i>	15
<i>Customer service and guarantee</i>	15
<i>Environmental protection and recycling</i>	15
<i>Exploded view of the unit</i>	16
<i>Spare parts list</i>	17
<i>Electrical wiring diagram CLK 80-RV</i>	18
<i>Electrical wiring diagram CLK 170-RV</i>	19
<i>Commissioning fan oil burner</i>	20-21
<i>Maintenance protocol</i>	22
<i>Technical data</i>	23



Carefully read this operating manual prior to commissioning / using the unit!

This operating manual is a translation of the German original.

These instructions are an integral part of the unit and must always be kept in the vicinity of the installation location or on the unit itself.

Subject to modifications; no liability accepted for errors or misprints!

REMKO CLK 80/170-RV

Safety notes

Always observe the respective local building code and fire prevention guidelines as well as the guidelines of the accident prevention and insurance associations as a basic rule when using the unit.

- The units may only be operated by persons that have been extensively instructed in the operation of the equipment
- The units must be installed in a stable position.
- The units must be installed and operated in such a way that personnel are not endangered by exhaust, warm air and radiant heat and no fires may occur
- The units must then only be operated in areas where the units can be supplied with an adequate amount of air for the combustion
- If the units are being operated without exhaust gas routing then they may only be operated in well ventilated areas. Under such circumstances it is forbidden for personnel to remain in these areas for extended periods. Appropriate prohibition signs should be put up at the entrances
- A safety zone of 1.5 m should be maintained around the units - incl. non-combustible items
- The units may only be installed on a level and non-combustible surface.
- The units may not be installed or operated in potentially flammable or explosive environments
- All electrical cables for the units must be protected against damage (e.g. by animals etc.)
- The units must not be exposed to direct jets of water, e.g. **pressure washers etc.**
- Portable fuel containers must only be set up and used in observance of the technical rules for combustible liquids "TRbF 20".
- Any additional conditions from the respective regional building regulations must be observed
- The protective grid of the unit's intake must always be kept free of dirt and loose objects
- Never stick foreign objects into the units
- The power plug must be pulled out of the mains socket before the start of work on the unit as a matter of principle
- Safety devices may be neither bypassed nor disabled
- The personnel tasked with operating the units must check the units for visible defects on the operating and safety devices as well as the presence of the protective devices at the start of work.
- In the case of defects that endanger the operational safety of the unit, it must be taken out of service immediately.

ATTENTION

The units may never be disconnected from the mains prior to the completion of the follow-up cooling phase (except in emergencies).

NOTE

Only type-approved forced-air oil burners in WLE design per DIN EN 267 should be used.

NOTE

For optimum operation the units should not be operated above an ambient temperature of 25 °C.

Unit description

The units are portable, directly fired fan-assisted heaters (WLE) with heat exchanger and exhaust gas connections exclusively for commercial applications.

The units are directly fired with EL heating oil or Diesel fuel.

The units can be operated with or without exhaust gas pipe (depending on the conditions on the customer's side). They have been designed for universal and straightforward use.

The units must be exclusively operated with separate type-approved forced-air WLE-type burners.

The units are equipped with a noise-optimised and low-maintenance, high performance radial fan, a room thermostat receptacle and a mains cable with a 230 V shock-proof plug or CLK 170-RV with 400 V CEE connector.

The CLK 170-RV units are equipped with a device for automatically checking the turning direction of the fan motor, as standard.

With factory fitted forced-air oil burners the CLK 170-RV units have integrated REMKO Multiflex oil pre-heating fitted as standard. With the CLK 80-RV this is available as an option (EDP no. 1071411).

The units conform to the fundamental health and safety requirements of the appropriate EU stipulations and are simple to operate.

Operating sequence

If the units are set to heating mode, then the forced-air burner starts automatically. In fully automatic heating mode with room thermostat the forced-air burner starts only when heat is required.

After the burner has run for a short time the temperature controller "TR" (target temperature ca. 40°C) switches the supply air fan on automatically. Warm air is blown out.

When operating with a room thermostat this process is repeated automatically depending on the heat demand.

The temperature monitor "TW" (target temperature 80 to 85°C) monitors the internal temperature of the unit.

After switching off the units via the operating switch or the room thermostats the supply air fan runs to cool the combustion chamber with the heat exchanger for a certain time and then switches off automatically.

This process may be repeated several times if necessary, depending on the temperature profile.

In simple ventilating mode the unit can be used to recirculate the air permanently. Thermostatic control is not possible in this case.

Locations at which units are used

As mobile, directly fired fan-assisted heaters, the units deliver instant heat. They are designed exclusively for commercial use, with and without warm air hoses.

The units may be used for the heating, temperature adjustment or drying of:

- Warehouses
- Exhibition halls
- Trade fairs
- Lightweight construction halls
- Large tents / marquees
- Large construction sites
- Building drying

REMKO CLK 80/170-RV

Installation instructions

The safety regulations of the accident prevention and insurance associations, the respective regional building regulations and the combustion appliances regulations apply in principle to the operation of the unit.



NOTE

Overpressure and underpressure in the installation area should be avoided as this will inevitably lead to combustion-related faults.

- Make sure that there is an adequate fresh air supply appropriate to the respective forced-air burner capacity (see name plate). The forced-air oil burner may need to be fitted with a separate air supply for combustion

Installation outside

- The operation of the units must not present a hazard or unreasonable loading
- The unit operator must ensure that it is not possible for unauthorised persons to be able to manipulate either the unit or the power supply.
- The unit must be protected from unauthorised use
- Precipitation such as rain or snow can be sucked in through the supply air fan. For this reason suitable weather protection should be provided.

Installation in closed, well ventilated areas without exhaust gas connection

- The operation of the units is permissible if the minimum air quantity for combustion is supplied.
- Reliable extraction of the combustion gases must be guaranteed in all cases in order to exclude impermissible contamination of the room air with hazardous substances.
Fresh air is fed from below. Exhaust gases are routed upwards.
- It is forbidden for personnel to remain in these areas for extended periods.
Appropriate prohibition signs should be put up at the entrances



ATTENTION

The units must only be installed in well ventilated spaces and not in living areas or similar recreational areas.

Room heating

- The units may only be operated for room heating with a room thermostat (accessory)
- The fresh air supply required for trouble-free combustion must be guaranteed. It is practical to have the fresh air supply provided by windows and doors or through appropriately dimensioned openings in the outside wall
- The exhaust gases must be fed to the outside via the flue gas pipes.

Safety distances

- In order to guarantee safe operation and maintenance of the units, 1.5 m safety distance should be maintained around the unit.
- Flooring and ceilings must be fire retardant
- Intake and outlet diameters must not be narrowed or blocked with foreign objects.

Safety equipment

Safety temperature limiter (STB)

The heating function is permanently interrupted by the safety temperature limiter (STB) in the event of the units overheating or malfunctioning.

Manually resetting of the STB can only be implemented after the units have cooled down.

The resetting of the STB is implemented by actuating the reset button 2.

ATTENTION

If the safety temperature limiter has been tripped then the cause of the malfunction should be identified and rectified before resetting it.

1. Unscrew protective cap [1].

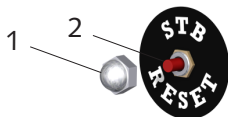

2. Carefully press in the reset button [2] with a suitable tool.
3. Screw the protective cap [1] back on again.

ATTENTION

Safety devices may be neither bypassed nor disabled.

NOTE

In order to prevent a renewed exceedance of the triggering temperature the operating conditions of the unit should be checked before resetting the STB.

Regulating device

The temperature sensor of the controller is self-monitoring. The probes are cold-resistant to -25 °C.

At temperatures below -25 °C the controller current flow will be interrupted - if the temperature rises above -25 °C the current flow will be released again.

In the event of the probe or the capillary tube being damaged, as well as if an overtemperature of ca. 220 °C is reached, the fill medium will be emptied and the safety device is permanently triggered. Resetting is no longer possible. The controller is no longer fully functional and must be replaced.

NOTE

Only "REMKO original replacement parts" must be used when replacing safety devices.

- Ensure that the device is fitted properly
- The capillary tubes must not be kinked or bent in the immediate vicinity of the soldering points
- The capillary tubes must not be damaged or kinked during installation
- The probes must only be fitted at the fastening points provided by the factory
- The probes must always be free of dust and dirt in order to be sure of their correct functioning

The units have the following control or safety equipment:

Temperature controller (TR)

The temperature controller controls the switching on and off of the recirculating fan. The switch point is set via the "Scale 21 - 60°" controller in the switching cabinet. Target value ca. 35 - 40 °C.

Temperature monitor (TW)

The temperature monitor limits the unit or outlet temperature in heating mode via the burner. The switch point is set via the "Scale 34 - 110°" controller in the switching cabinet. Target value ca. 80 - 85 °C.

Safety temperature limiter (STB)

The unit is permanently switched off by the safety temperature limiter (STB) in the event of the unit overheating or a temperature monitor malfunction. Manual resetting is required.

Automatic burner

The unit is permanently switched off by the automatic burner through the optical flame monitoring in the event of irregularities in the combustion, the flame extinguishing, fuel deficiencies etc. Manual resetting is required.

REMKO CLK 80/170-RV

Exhaust ducting

It is also possible to operate the units outside or in open rooms / halls without exhaust gas routing.

However, we recommend fitting a 1m exhaust gas duct with a rain hood on top (example 2), in order to exclude the ingress of rainwater and dirt.

If the units are used for room heating then the combustion gases must be routed away, to the outside if necessary.

- The exhaust gas routing must be designed such that the thermal lift of the exhaust gases is guaranteed at all times
- Die The exhaust gas routing must be designed such that there can be no counter-pressure

- Fault-free operation is guaranteed if the exhaust gas routing is fitted in a rising arrangement and with a vertical end pipe

- The exhaust gas routing should end at least above the height of the eaves but ideally above the height of the ridge, in order to prevent any counter-pressure being caused by poor weather conditions (e.g. wind)

- The minimum distance of 0.6 m to combustible parts must not be infringed

- Exhaust gas ducting parts and fastening materials are available as accessories

- All parts of the exhaust gas routing must be reliably fastened. Its diameter must not be smaller than the outlet nozzle of the unit.

⚠ ATTENTION

There must be no counter pressure arising from incorrect installation of exhaust gas ducting under any circumstances.

Notes for implementing the 1st. BImSchV

Units that are not expected to be operated for longer than 3 months in the same location are not subject to any approvals or monitoring per the 1st. BImSchV. (§1, section 3)

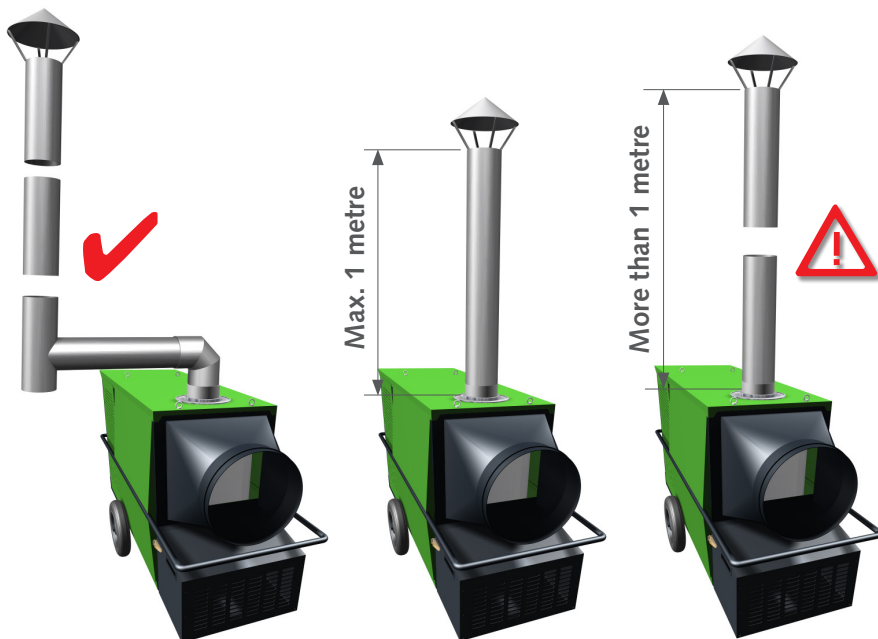

Example 1
Operation with extended exhaust gas ducting

Condensate trap required.

Example 2
Operation without extended exhaust gas ducting.

Max. 1 metre

Example 3
Impermissible arrangement

In order to avoid the combustion chamber being damaged due to condensation of moisture (condensate) in example 3, make sure that the exhaust gas ducting is correctly installed with a condensate trap as shown in example 1.

💡 NOTE

After installing an exhaust gas system the settings on the burner should be adapted to suit the new conditions.

Before commissioning

The units should be checked for visible defects on the operating and safety devices as well as proper installation and correct electrical connections before commissioning.

It is essential that the following points be observed:

- The units must be installed in a stable position
- Ensure there is sufficient supply of combustion air
- Check that the inlet and outlet are free
- Prevent overpressure or underpressure in the installation area
- Ensure that there is sufficient fuel supply and that it complies with the respective local regulations
- Only use clean EL heating oil or Diesel fuel. **Do not use Bio-Diesel!**
- The suction pipe in the base of the tank must be fitted with a foot valve as a matter of principle

NOTE

After fulfilling the respective local regulations as well as a professional installation of the unit, the exhaust values for the forced-air burner must be checked and adjusted if necessary by authorised specialists.

NOTE

Air feeds on the intake side must always be implemented by means of non-distorting hoses/ducts (no unstable hoses).

Air distribution

The units are equipped with a high performance radial fan, which has been designed to transport the heated air efficiently and effectively over large distances.

The distribution of the air is preferably implemented via ducting or special warm air or membrane hoses.

- Use hot air hoses approved by us (accessories) exclusively
- Observe the air flow direction of the hoses with this! The inner overlapping on the seams of the hot air hoses must point in the direction of the air flow.
- Make sure that the hose or ducting is securely fastened onto the unit outlet nozzle and any connection pieces that may be being used
- Only suitable air distributors or air distributors approved by ourselves should be used for the air distribution

NOTE

The hot air hoses must only be used in fully extended form and without any constrictions.

- Enclosed spaces being heated via hoses must not present any overpressure
- The forced-air burner can be switched off briefly during operation by the temperature monitor (TW) in the event of there being increased intake temperatures or resistance at the unit's outlet.
After the temperature drops again the burner starts anew automatically!

- If the cycle intervals are too short the length and layout of the hot air routing should be checked

NOTE

Cycled operation of the forced-air burner with run times under 5 min. should certainly be avoided.

- There should be no kinks or bends in the layout of the hoses in order to prevent hot-spots forming. Membrane hoses must not be twisted

ATTENTION

If a build-up of heat should occur then the heating operation will be interrupted by the STB permanently.

Suction air

Fresh air, mixed air or circulated air operating modes can be selected on the unit. The following information refers to the installation of the unit outside the space to be heated.

Fresh air operation:

The air intake is implemented in the factory through 2 intake grills, right / left.

Mixed air operation:

For operation of the unit in mixed air mode it is necessary to fit the intake nozzles, available as accessories.

In order to guarantee adequate air throughput the second intake grill must not be covered.

Circulated air operation:

For operation of the unit with 100% recirculated air it is necessary to fit two intake nozzles, available as accessories, in place of the 2 factory-fitted intake grills.

REMKO CLK 80/170-RV



Paraffin formation with low outside temperatures

Even at low outside temperatures it is necessary to ensure that there is an adequate supply of heating oil that is capable of flowing.

- Paraffin formation can start with temperatures as high as 5 °C
- To avoid this appropriate preventative measures must be implemented.
e.g. **Winter-proof EL heating oil or winter Diesel, heated oil tank, insulated oil lines etc.**
- Note that fault-free operation of the Multiflex oil pre-heating can only be guaranteed if the unit has been supplied with electrical power for a long period of time before starting
- It is not possible to rectify paraffin separation that has already occurred with the heating. If paraffin has already formed it is necessary to clean out the complete fuel system

NOTE

Paraffin formation can start with temperatures as high as 5 °C. To avoid this appropriate preventative measures must be implemented, e.g. winter Diesel.

Commissioning

One person, who has been adequately trained in the handling of the unit, should be tasked with the operation and monitoring of the unit.

Connecting the units with the electrical power supply

The electrical connection is made using a built-in mains cable with plug.

1. Move the operating switch to the "0" (off) position. 
2. Connect the power plug with a properly installed and appropriately safeguarded mains socket **230V or shock-proof 400V/3~N/50Hz**.
3. Open all of the oil supply shut-off devices.
With the initial commissioning, air in the lines can lead to a fault shut-down of the burner.

NOTE

The electrical connection for the units must be made at a separate feedpoint with a residual current device in accordance with VDE 0100, Section 55.

ATTENTION

All cable extensions must only be used in fully un-reeled or reeled off condition.

NOTE

The 400V version of the unit is equipped with a device for automatically checking the turning direction of the fan motor, as standard.

Control panel

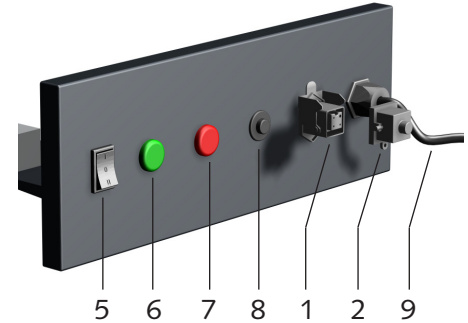



- 1 = Thermostat receptacle
- 2 = Strapping plug
- 5 = Operating switch
- 6 = Indicator light "GREEN" "Operation"
- 7 = Indicator light "RED" "Burner fault"
- 8 = Reset button "Burner"
- 9 = Mains cable with plug

Heating without room thermostat

The units are operating in permanent operating mode.

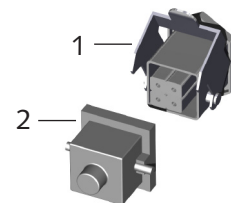
1. Connect the strapping plug supplied [2] with the thermostat receptacle [1] on the unit.



2. Move the operating switch to the "I" (on) position. 

Heating with room thermostat (Accessories)

The units operate fully automatically and exclusively in accordance with the room temperature.

1. Pull out the strapping plug [2].
2. Connect the room thermostat [4] plug [3] with the thermostat receptacle [1] on the unit.

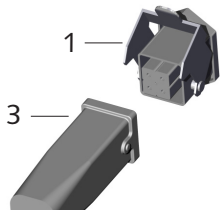

3. Place the room thermostat [4] at a suitable location in the room.
The thermostat sensor must not be located directly in the warm air flow and should also not be placed directly on the cold floor.
4. Set the desired temperature on the room thermostat [4].

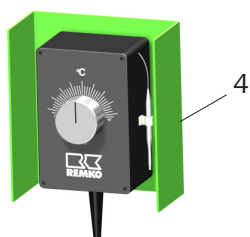

5. Move the operating switch to the "I" (Heating) position.

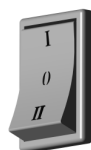

The unit starts automatically after a brief burner pre-ventilation if heat is required and then runs fully automatically.

Ventilate

In this switch position the supply air fan runs permanently. The units can be used for air recirculation or ventilation purposes.

1. Move the operating switch to the "II" (Ventilate) position.



Thermostatic control as well as heating operation is not possible in this operating mode.

NOTE

Indicator light "Operation"
The indicator light signals the "Heating" operating mode. There is no display in the "Ventilate" operating mode or with the room thermostat switched off and when the STB has been triggered.

ATTENTION

The thermal overcurrent relay must be operated exclusively in the "Manual resetting" position. It is not permitted for the relay to be able to switch itself back on again after the cooling down phase.

NOTE

If the overcurrent relay is operated in the "Automatic resetting" position, then motor damage cannot be excluded.
Guarantee claims are voided!

Shutdown

1. Move the operating switch to the "0" (off) position.



2. Shut off fuel supply.



3. With longer periods of inactivity, disconnect the units from the mains power supply.

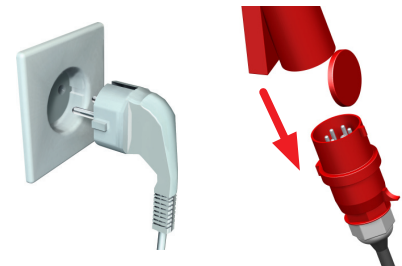

The supply air fan runs on to cool the combustion chamber and the heat exchanger and only switches off after the cooling down phase is complete. The fan can switch on and run several times before the final shutdown.

ATTENTION

Never interrupt the power supply prior to the completion of the follow-up cooling phase.
There is no warranty claim for damage to the units from overheating.

NOTE

The burner setting should be checked after every change of location and adapted to the new environmental conditions and atmospheric conditions if necessary.

REMKO CLK 80/170-RV

Care and maintenance

Regular care and observation of some basic points will ensure trouble-free operation and a long service life.

⚠ ATTENTION

The power plug must be pulled out of the mains socket before the start of work on the unit as a matter of principle.

💡 NOTE

Adjustment and maintenance work may only be carried out by authorised qualified technicians.

- Keep the units free of dust and other debris
- Only clean the units with a dry or moistened cloth
- Never subject to direct jets of water.
such as a high-pressure cleaner etc.
- Never use abrasive or solvent-based cleaners
- Use only suitable cleaners for heavy contamination
- Only use clean EL heating oil or Diesel fuel.
Watch for paraffin formation!
- Check the fuel filter for contamination at regular intervals.
Replace contaminated filters immediately
- Check the units for mechanical damage and have defective parts properly replaced

- Check the fan blades and combustion chamber with heat exchanger for contamination at regular intervals and clean these if necessary
- Check the on-site oil tank regularly for contamination and foreign bodies and clean this if necessary
- Inspect V-belt pre-tensioning. The press-down deflection depth for the V-belts should be ca. 10 mm (a thumb width)
- Check that the safety devices are operating correctly at regular intervals
- Keep the probes for the safety devices free of dust and dirt
- Have the exhaust gas values for the forced-air burner checked by authorised specialists at regular intervals. For safety reasons we recommend the conclusion of a maintenance contract.
- Observe maintenance and care intervals

Cleaning tasks

The units, including the heat exchanger, combustion chamber and forced-air burner must be cleared of dust and dirt after every heating period, or possibly earlier depending on the operating conditions.

Wearing parts, such as exhaust gas suppressors, seals, V-belts, oil filter inserts and oil nozzles for example, should be checked and replaced if necessary.

Cleaning the heat exchanger

1. Set the operating switch to the "0" position and remove the power plug from the mains socket.
2. Take off the exhaust hood [1] after removing the 4 fastening screws. Hot air hoses present need not necessarily be removed.
3. Remove the inspection cover [2] and withdraw the exhaust gas suppressors 4.
4. Clean the flue [5].
A special cleaning brush is available as an accessory with EDP no. 1103110.

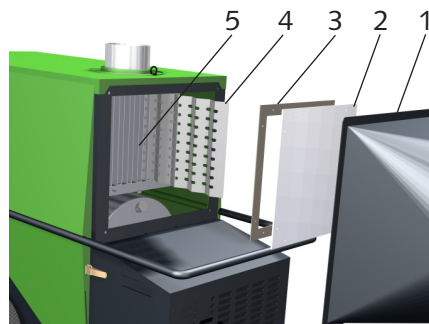

5. Clean the exhaust gas suppressors or replace damaged exhaust gas suppressors.
6. Check the seal [3] for the inspection cover and replace any damaged seals.
7. After the maintenance work is complete all parts should be carefully re-fitted in reverse order.

💡 NOTE

Always check that the seal is correctly seated in the inspection cover.

When fitting the inspection cover ensure that the fastening screws are tightened evenly.

Cleaning the combustion chamber

1. Set the operating switch to the "0" position and remove the power plug from the mains socket.
2. Remove the burner cladding [1] after opening the two quick couplings [2].



3. Loosen the 2 lower fastening screws on the burner flange [6].
4. Loosen the clamping screw [7] on the burner flange 6 and withdraw the burner towards the front.

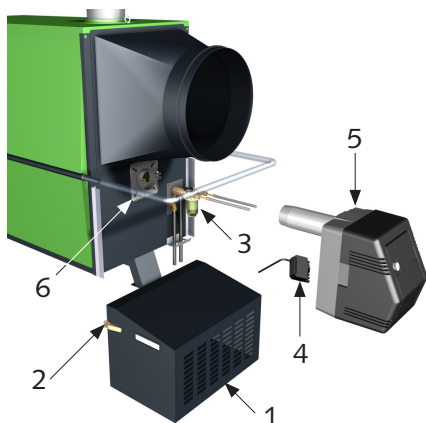

5. Withdraw the burner and carefully set it down beside the unit.
6. Remove the burner flange [6].
7. Take care not to damage the flange seals, as far as is possible.
Damaged flange seals can result in incorrect air induction.
8. Clean the combustion chamber through the burner opening with a vacuum cleaner. A special boiler cleaning set for the REMKO industrial vacuum cleaner is available as an accessory.

Installation of the burner flange and the burner

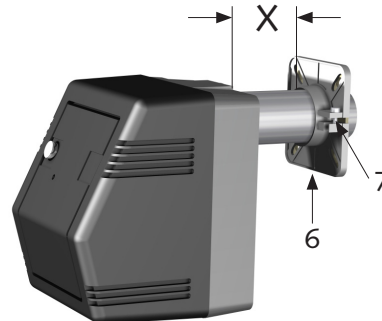

Burner CLK 80-RV: **X = 20 mm**
Burner CLK 170-RV: **X = 30 mm**

1. Check the flange seal and replace if necessary.
2. Fasten the burner flange to the unit housing with the four fastening screws.
Note the "UP" marking!
3. Tighten the top 2 fastening screws firmly.
4. Tighten the lower 2 fastening screws gently and with only light force so that the burner flange can still be pulled together.
5. Slide the flame tube of the burner into the burner flange.
Observe dimensions in the sketch!
6. Clamp the flame tube firmly into place with the clamping screw [7] whilst lifting the burner slightly (3° tilt).
7. Lastly, tighten the bottom 2 fastening screws firmly.
8. Check the fuel filter insert [3] for leaks and replace if necessary.
9. Re-fit burner cladding and fasten with the quick couplings.

Additional notes for unit maintenance

- All work must be carried out exclusively by authorised specialists with the appropriate equipment. A log should be created and kept safely by the operator
- It is essential that the forced-air burner is serviced and adjusted by authorised specialists

⚠ ATTENTION

Repair work on the electrical installation and on the burner must be performed exclusively by authorised specialists for safety reasons.

⚠ ATTENTION

An electrical safety check must be carried out in accordance with VDE 0701 after any work on the units.

💡 NOTE

The restrictions on exhaust gas losses per §11 of the ordinance on small furnace systems (1st. BImSchV) must be observed.

REMKO CLK 80/170-RV



Tensioning the V-belt

1. Remove the two side air intake grills.
2. Loosen the screws (size 13) [7]. The screw on the opposite side is not shown.
3. Set the pre-tension of the V-belt with the (size 17) nuts [8] and [9].
4. The press-down deflection depth for the V-belts should be ca. 10 mm, "a thumb width".
5. Counter-lock the nuts [8] and [9] again and then tighten the two fastening screws [7] again.
6. Re-fit the two air intake grills.

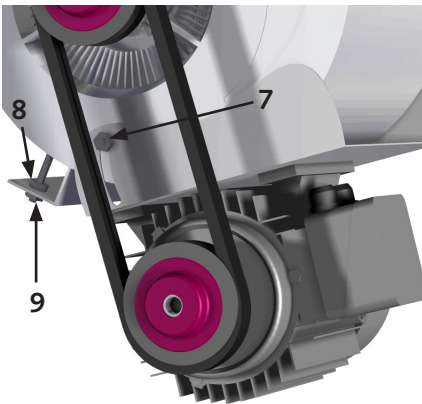

NOTE

The press-down deflection depth for the V-belts should be ca. 10 mm (a thumb width).

Troubleshooting

⚠ ATTENTION

Before undertaking any work on the units, the power plug must be removed from the mains socket.

The unit does not start

1. Check power supply. 400 V/3~N/50Hz.
2. Move the operating switch to the "I" (Heating) position.
3. The "Operating" indicator light on the control panel must illuminate.
4. Check the strapping connector or the room thermostat plug, if fitted, is seated properly and making good contact.
5. Check the setting of the room thermostat. The temperature set must be higher than the current room temperature.
6. Check whether the safety temperature limiter (STB) has tripped. To do so, remove the protective cap next to the control panel.
7. Before an STB reset ensure that the causes have been analysed and rectified. The following causes are possible:
 - The units were not able to cool down because the electrical connection was interrupted.
 - Too high an outlet temperature due to incorrectly implemented air routing when operating with hoses.
 - Air inlets or outlets are not free or are inadequate.
8. Check whether the "Burner fault" indicator light on the control panel is illuminated. If this is the case, then reset the automatic burner.
9. Move the operating switch to the "II" (Ventilate) position. If the supply air fan now starts up the fault may well be in the burner area.

Forced-air burner and power supply

1. Check the oil filter(s) for contamination. Replace contaminated oil filter(s).
2. Check whether the shut-off cock on the oil filter is open.
3. Check the fuel tank for sufficient fuel level.
4. Check the heating oil for paraffin separation. **Possible from 5 °C!**
5. Check the oil hoses for damage.
6. Check the safety devices' capillary tubes and probes for damage or contamination.
7. Use appropriate means to check that the temperature monitor (TW) is functioning properly.
8. Check the forced-air burner for possible damage to the nozzles, baffle plate, filter etc.

The supply air fan does not start

1. Check the fan can move freely.
2. Check the controller fuse in the switching cabinet.
3. Check whether the motor protection switch in the switching cabinet has tripped.
4. Use appropriate means to check that the temperature controller (TR) is functioning properly.

Intended use

The units are designed exclusively for heating and ventilation purposes in industrial or commercial use (no living space heating in private use) on the basis of their structural design and equipment.

The units must only be operated by appropriately instructed personnel.

With non-observance of the manufacturer's specifications, the respective local legal requirements or after arbitrary alterations to the units, the manufacturer shall not be liable for resulting damages.



NOTE

Operation other than the types listed in this operating manual is prohibited. With non-observance, any liability and claim to guarantee expire.



ATTENTION

*Copyright
The redistribution, even in part, or the use of this documentation for purposes other than intended is strictly prohibited without the written authorisation of
REMKO GmbH & Co. KG*

Customer service and Guarantee

As a prerequisite for any guarantee claims to be considered, it is essential that the ordering party or its representative complete and return the "**certificate of guarantee**" to REMKO GmbH & Co. KG at the time when the units are purchased and commissioned.

The units were tested at the factory several times to verify their correct function.

However, if malfunctions should arise that cannot be remedied by the operator with the assistance of the troubleshooting section, please contact your specialist dealer or contractual partner.



NOTE

Adjustment and maintenance work may only be carried out by authorised qualified technicians.



Environmental protection and recycling

Disposing of packaging

When disposing of packaging material, please consider our environment.

Our units are carefully packed and delivered in sturdy transport packaging made from cardboard and on a wooden pallet.

The packaging materials are environmentally-friendly and can be recycled.

By recycling packaging materials, you make a valuable contribution to the reduction of waste and conservation of raw materials.

Therefore, only dispose of packaging material at appropriate collection points.

Disposal of the old unit

The manufacturing process for the units is subject to continuous quality control.

Only high-grade materials are processed, the majority of which are recyclable.

You also contribute to environmental protection by ensuring that your old equipment is only disposed of in an environmentally-friendly manner.

Therefore, only bring the old unit to an authorised recycling business or to an appropriate collection point.

REMKO CLK 80/170-RV

Exploded view of the unit

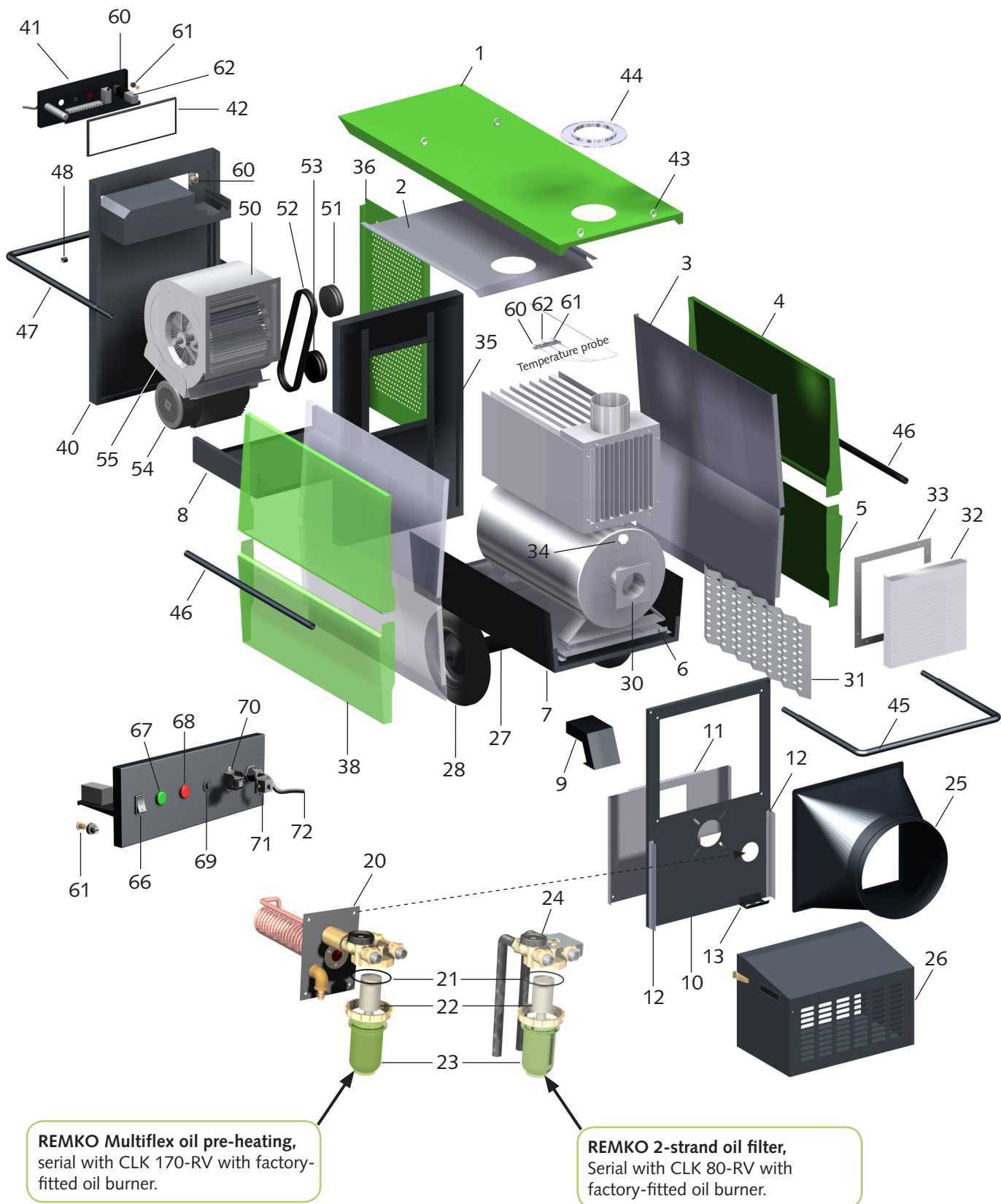

Spare parts list

No.	Description	CLK 80-RV	CLK 170-RV
01	Cover panel	1104740-1	1104851
02	Upper insulation	1104741-1	1104852
03	Insulation right / left	1104742	1104853
04	Upper side cover (right / left)	1104743	1104854
05	Lower side cover (right / left)	1104744-1	1104855
06	Lower insulation	1104746	1104872
07	Base tray, front	1104745	1104856
08	Base tray, rear	1104836	1104857
09	Support foot	1104790	1104790
10	Front wall compl.	1104755	1104858
11	Front wall insulation	1104756	1104786
12	Guide bracket	1104757	1104787
13	Hose pass-through	1104722	1104722
20	Multiflex oil pre-heating, compl.	1071411	1071411
21	O-ring	1108464	1108464
22	Filter insert	1108462	1108462
23	Oil filter cup	1108463	1108463
24	Oil filter, compl.	1002526	—
25	Outlet nozzle	1104758	1104788
26	Burner cladding compl.	1104759	1104789
27	Axle	1104760-1	1104791
28	Wheel	1108369	1108369
30	Combustion chamber, compl.	1104761-2	1104806-2
31	Exhaust gas suppressor (set)	1104793	1104810
32	Inspection cover	1104763	1104794
33	Seal for inspection cover	1104764	1104795
34	Sealing cap	1104728	1104784
35	Centre wall	1104841	1104862
36	Intake grill, right / left	1104842	1104863
40	Back wall	1104843	1104864
41	Switching cabinet compl.	1104783-1	1104865
42	Seal for switching cabinet	1104754	1104866
43	Crane eye	1102554	1102554
44	Exhaust gas nozzle collar	1104732	1104796
45	Transportation bracket, front	1104765	1104867
46	Transportation bracket, middle	1104767	1104868
47	Transportation bracket, rear	1104766-1	1104869
48	Spacing roller	1104849	1104849
50	Radial fan	1108603	1108607
51	Fan belt pulley	1113111	1102777
52	V-belt	1113112	1102774
53	Motor belt pulley	1113110	1102784
54	Electric motor IE2	1102737	1102733
55	Motor bracket with clamp	1104850	1104870
60	Temperature controller (TR)	1103166	1103166
61	Safety temperature limiter (STB)	1101197	1101197
62	Temperature monitor (TW)	1103146	1103146
66	Operating switch	1101188	1101188
67	Indicator light, green (Operation)	1105514	1105514
68	Indicator light, red (Burner fault)	1105363	1105363
69	Reset button (Burner)	1103408	1103408
70	Thermostat receptacle	1101018	1101018
71	Strapping plug	1101019	1101019
72	Mains cable with plug	1104701	1105100
Not shown	Burner connector, 7-pole	1102537	1102537
Not shown	Drum fitting, compl.	1002544	1002544
Not shown	Cleaning brush, compl.	1103110	1103110
Not shown	Locking ring	1101622	1101622
Not shown	Hubcap	1101623	1101623

When ordering spare parts, please state the EDP no., unit number and type (see name plate)!

REMKO CLK 80/170-RV

Electrical wiring diagram CLK 80-RV

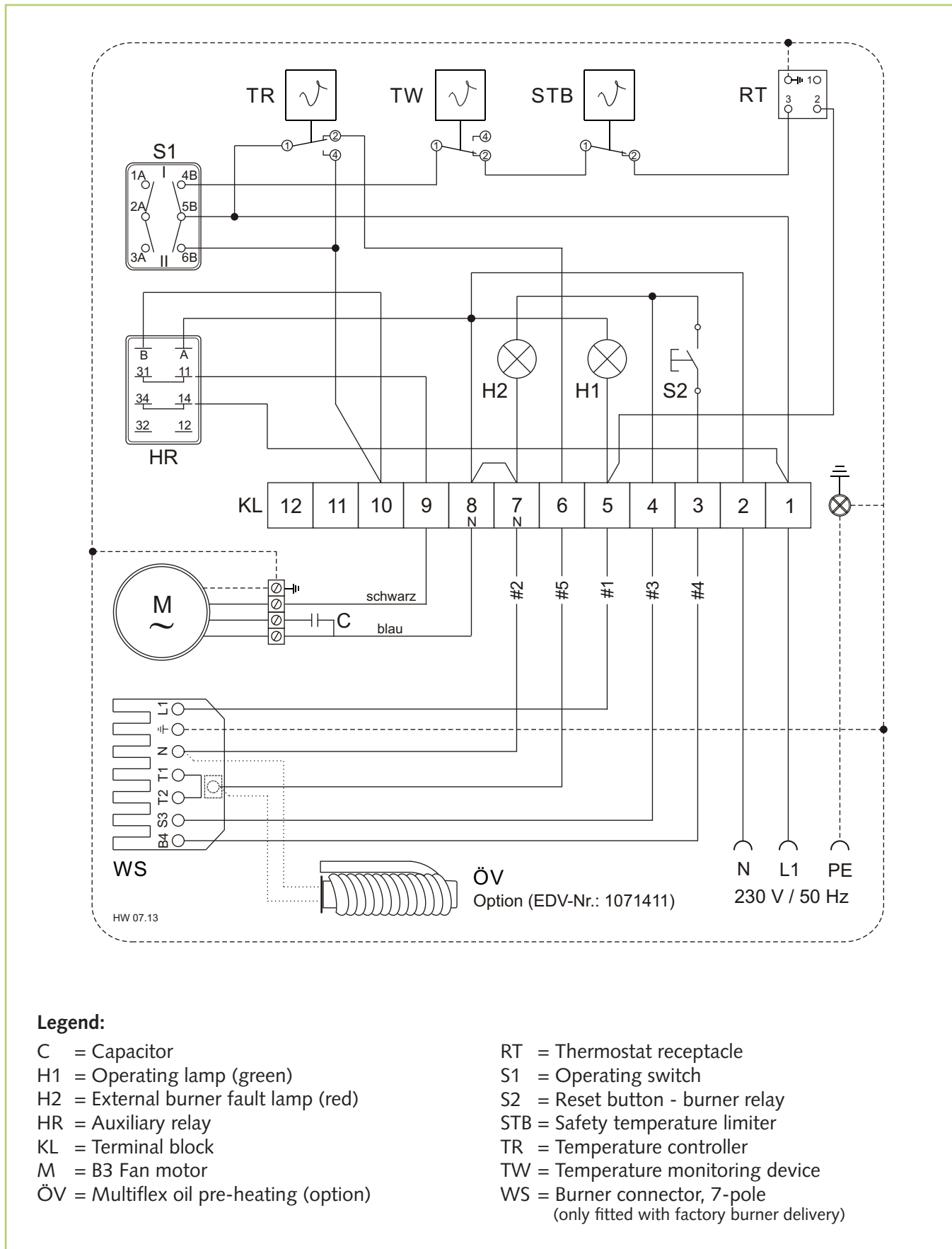

We reserve the right to modify the dimensions and design as part of the ongoing technical development process.

Electrical wiring diagram CLK 170-RV

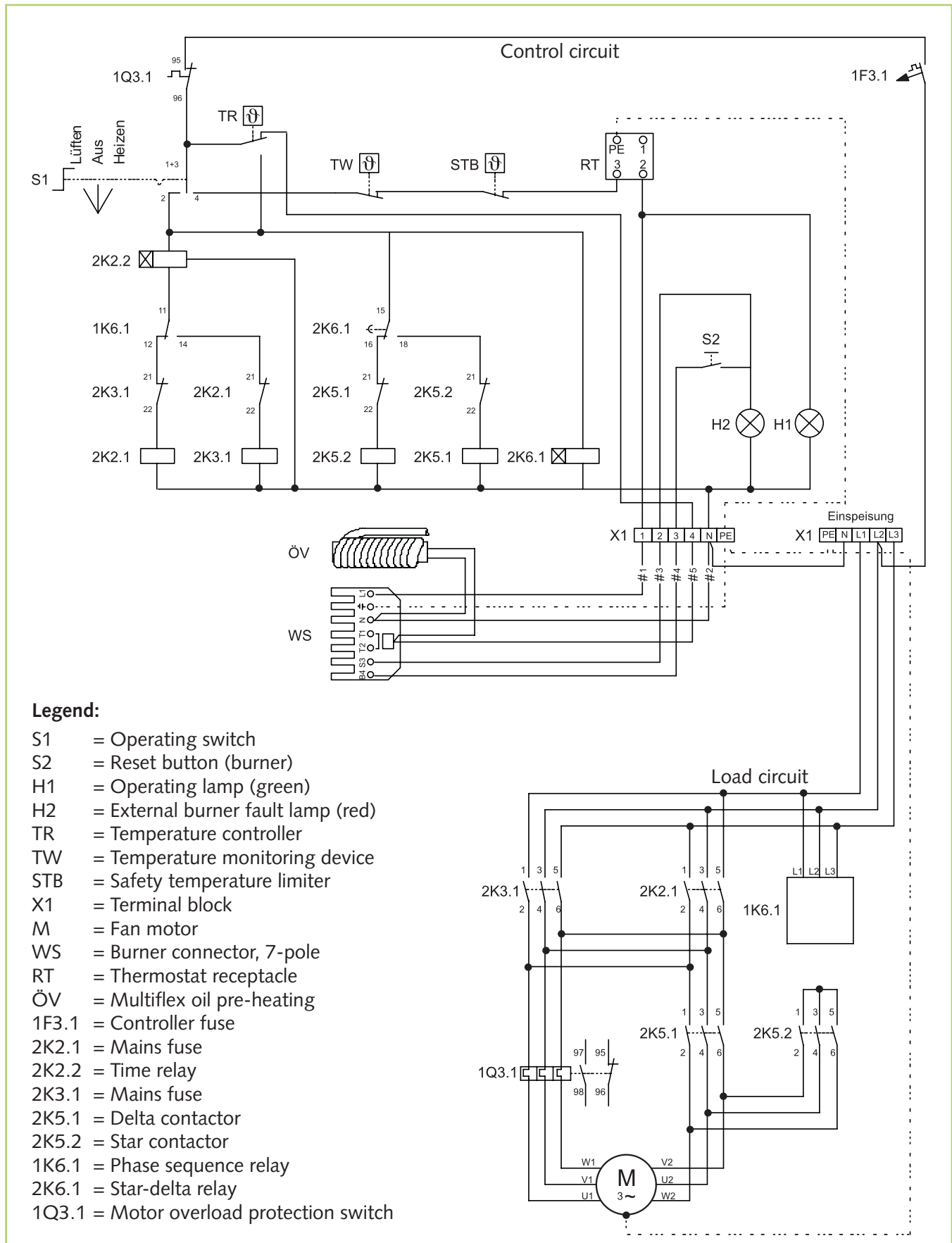

We reserve the right to modify the dimensions and design as part of the ongoing technical development process.

REMKO CLK 80/170-RV

Commissioning the forced-air oil burner

Preparatory tasks

⚠ ATTENTION

The commissioning of the forced-air oil burner may only be carried out by trained specialists.

After loosening the 4 fastening bolts the mounting baseplate M is pulled off the housing G.

From size SL 44, 6 fastening screws must be removed (note marking arrows).

💡 NOTE

Because the air flap, up to size 44, is sprung this should be closed beforehand with the help of the adjustment screw [3] (turn adjusting screw approx. as far as scale value 1).

The most important functional parts for the installation / maintenance are now immediately accessible, as per the respective requirements.

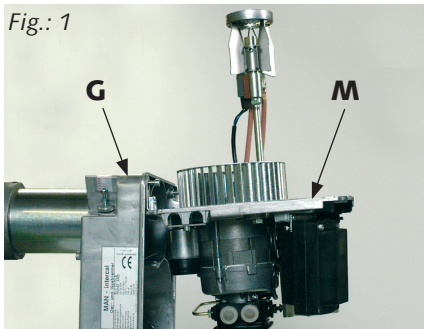

For maintenance work or for installing / replacing the oil nozzle, the mounting baseplate M can be positioned on the burner housing G in 2 ways (see figs. 1 and 2).

The baseplate can be positioned in the desired / possible position on the special mounting points in accordance with the unit-specific options.

Adjusting the ignition electrode and baffle plate

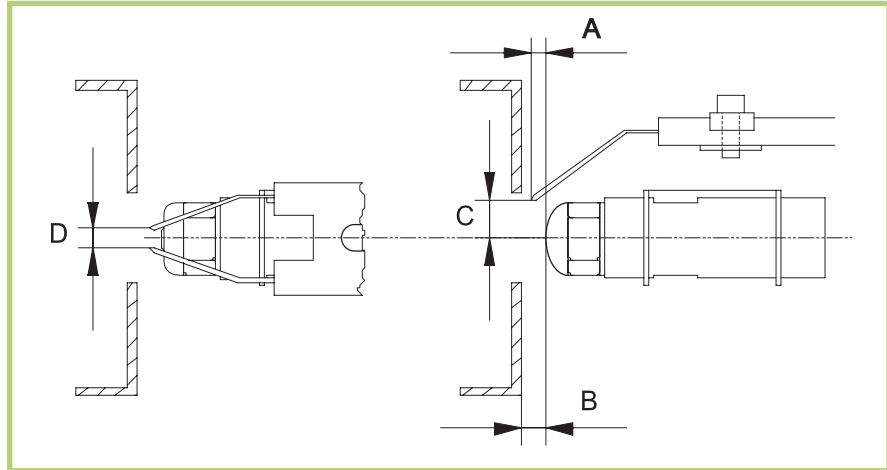

Size / dimensions	A	B	C	D
CLK 80-RV	5	5	7	3
CLK 170-RV	7	8	5	3

All sizes are approximate values and are in mm. The optimum setting must be adapted to the unit-specific and structural conditions.

Required nozzle size

The selection of the required oil nozzle is dependent on the pump pressure and the unit capacity. Only a nozzle that is approved for the respective combustion chamber geometry with corresponding spray angle and cone characteristics may be used.

Refer to the technical data for the required oil nozzle size.

Air inlet nozzle

The required blower pressure can be adjusted with the adjustable air inlet nozzle A in accordance with the combustion chamber resistance and chimney draft, without having to change the output diameter.

1. Loosen the Allen screw B.
2. Turn the air inlet nozzle A to the desired position (note arrows!).

"min" = Smaller blower pressure

"max" = Larger blower pressure

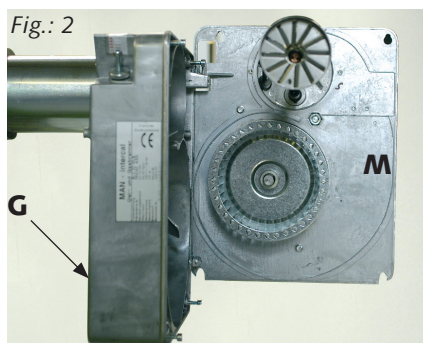
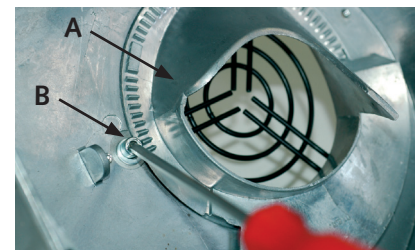

Mounting baseplate

After having replaced the nozzle and carried out any adjustments required to the air inlet nozzle A, the mounting baseplate M is re-fitted in reverse order.

Adjusting the secondary air (Nozzle fitting adjustment)

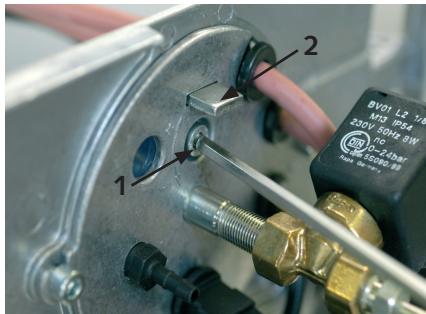

Carry out the presetting of the secondary air as follows:

Set the nozzle fitting 2 to the desired value with the adjusting screw 1.

CLK 80-RV

Turning to the left (-)
= smaller scale value
larger pressure behind the baffle plate
lower power range

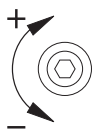

Turning to the right (+)
= larger scale value
smaller pressure behind the baffle plate
upper power range

CLK 170-RV

Turning to the left (+)
= larger scale value
smaller pressure behind the baffle plate
upper power range



Turning to the right (-)
= smaller scale value
larger pressure behind the baffle plate
lower power range

Air flap

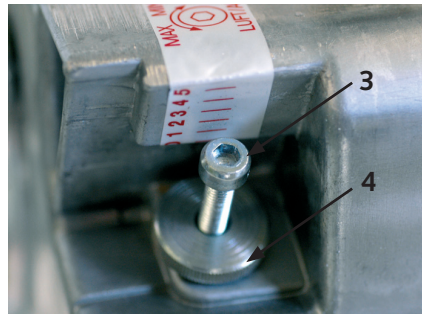

The quantity of combustion air required is adjusted by means of the adjusting screw 3. The air flap is set according to the unit capacity and the further burner settings.

Adjusting the air flap

Adjust the air flap as follows:

1. Loosen the knurled nut 4.
2. Set the adjusting screw 3 accordingly.

Turn to the right = Less air

Turn to the left = More air

4. After having set the adjusting screw 3 lock it again with the knurled knob 4.

Additional notes

- If the flame should give off sooty smoke or break away with a fully opened air flap, reduce the pressure behind the baffle plate with the help of the secondary air setting
- It may also be necessary to open the air inlet nozzle further

Setting the pump pressure

The pump pressure should be adjusted, and checked if necessary, during burner commissioning and during every service.

NOTE

Never let the pump run for extended periods without any fuel. Never leave the units for extended periods with a pump that has run dry.

Adjust the pump pressure as follows:

1. Remove the stopper on the measurement nozzle "P".
2. Fit a suitable oil pressure manometer here.
3. Open all oil shut-off devices.
4. Switch on the burner.
5. Set the required oil pressure in accordance with the nozzle size and the unit capacity.
6. Switch off the burner after completing the adjustments.
7. Remove the oil pressure manometer again. Re-fit stopper incl. seal.

ATTENTION

If the burner should carry out a fault shut-down once again after the start phase, then another reset should be carried out after a waiting period of 5 minutes has passed.

Further reset procedures must be prohibited as there is a danger of deflagration.

REMKO CLK 80/170-RV



Maintenance protocol

Unit type: Unit number:

	1	2	3	4	5	6	7	8	9	10	11	12	13	14	15	16	17	18	19	20
Unit cleaned - outside -																				
Unit cleaned - inside -																				
Fan blade cleaned																				
Combustion chamber cleaned																				
Heat exchanger cleaned																				
Exhaust gas suppressors replaced																				
Inspection cover seal replaced																				
Fuel filter insert replaced																				
Safety equipment checked																				
Safety devices checked																				
Unit checked for damage																				
Electrical safety check																				
Burner maintenance *)																				
Test run																				

Comments:

1. Date: Signature	2. Date: Signature	3. Date: Signature	4. Date: Signature	5. Date: Signature
6. Date: Signature	7. Date: Signature	8. Date: Signature	9. Date: Signature	10. Date: Signature
11. Date: Signature	12. Date: Signature	13. Date: Signature	14. Date: Signature	15. Date: Signature
16. Date: Signature	17. Date: Signature	18. Date: Signature	19. Date: Signature	20. Date: Signature

*) Have the forced-air burner maintained and adjusted only by authorised specialists and in accordance with the legal provisions (1st. BImSchV.). A corresponding measurement log should be generated.

Unit to be maintained only by authorised specialists in accordance with the statutory regulations.

Technical data

Unit type		CLK 80-RV	CLK 170-RV
Max. nominal heating capacity	kW	84	155
Nominal heat capacity	kW	77	143
Nominal flow rate ¹⁾	m ³ /h	6,140	10,340
(Max. total) pressure	Pa	410	520
Fuel		Heating oil EL acc. to DIN 51603-1 or diesel fuel	
Max. fuel consumption	l/h	8.3	15.5
Danfoss oil nozzle ²⁾	USG	1.75 / 60°S	3.00 / 80°S
Pump pressure, approx. ²⁾	bar	12	13
Max. exhaust gas loss	%	9	9
Exhaust gas flow, approx.	kg/h	136	240
Combustion chamber resistance, approx.	Pa	100	110
Required chimney draft	Pa	0	0
Power supply	V/Hz	230/1~/50	400/3~N / 50
Max. power consumption (complete unit)	kW	1.75	3.4
Max. nominal current (complete unit)	A	9.5	8.0
Max. power consumption (Multiflex oil preheating)	W	--	30
Customer-provided electrical protection	A	16	16
Temperature increase (Δt)	K	48	54
Sound pressure level L_{pA} 1m ³⁾	dB (A)	62	65
Air outlet \varnothing	mm	400	500
Air intake \varnothing ⁴⁾	mm	2 x 400	2 x 500
Exhaust gas nozzles \varnothing	mm	150	200
Dimensions: Length	mm	2,000	2,380
Width	mm	800	920
Height	mm	1,160	1,350
Weight with forced-air oil burner	kg	234	375
EDP no.: (with/without oil burner)		131300/131100	131700/131500

1) At Δt 45K / 1.2 kg/m³)

2) The specified nozzle sizes and pump pressures are based on test bench results.

The oil flow rate was derived from this.

Based on the product-specific nozzle and pressure tolerances as well as the oil temperature, the specifications should only be considered guidelines.

3) Noise level measurement (with hose and without burner operation) DIN 45635 - 01 - KL 3

4) Only with intake ports (accessories) for recirculating or mixed air operation

REMKO INTERNATIONAL

*... and also right in your neighbourhood!
Take advantage of our experience and advice*



REMKO GmbH & Co. KG Klima- und Wärmetechnik

Im Seelenkamp 12 D-32791 Lage
Postfach 1827 D-32777 Lage
Telephone +49 5232 606-0
Fax +49 5232 606-260
e-mail info@remko.de
Internet www.remko.de

Consulting

Thanks to intensive training, our consultants are always completely up-to-date when it comes to technical expertise. This has given us the reputation of being more than just an excellent, reliable supplier: REMKO, a partner who helps to solve problems.

Sales

REMKO offers not just a well-established sales network both nationally and internationally, but also has exceptionally highly-qualified sales specialists. REMKO employees in the field are more than mere salespeople: above all, they must be advisers to our customers in air conditioning and heating technology.

Customer service

Our units operate precisely and reliably. However, in the event of a malfunction REMKO customer service is quickly on the scene. Our comprehensive network of experienced dealers guarantees quick and reliable service.

